



Summary Slides

Our Own Debutante Party for a Special Young Lady – “ROZ”

A Recap of the 2010 Field Trip to
Hess Corporation's Seminole San
Andres Unit CO₂ Flood and Facilities
And Legado Resource's Goldsmith
Landreth CO₂ Flood (Ector Co, Tx)

December 8, 2010



A Very Special Thanks Goes to the Conference Sponsors

Advanced Resources International
Anadarko Petroleum
Apache Corporation
Applied Petroleum Technology Academy
Denbury Resources
Enhanced Oil Recovery Institute
Exxon Gas & Power Marketing
Hess Corporation
KinderMorgan CO₂ Company
Legado Resources
Midland College's Petroleum Professional
Development Center
NCG Consulting Group
Oxy Permian
Russell K Hall and Associates
Society of Petroleum Engineers, PB Section
Trinity CO₂, LLC
The University of Texas of the Permian Basin
Whiting Petroleum Corporation



Russell K. Hall and Associates, Inc.
Reservoir Evaluation Engineers



2010 CO₂ Flooding Conference Wednesday, Dec 8th

CO₂ Conference Field Trip to Seminole and Goldsmith

Clothing Requirements: If you have fire-retardant clothing, please wear; if not, wear long sleeve cotton shirt and cotton pants. You need to also wear sturdy, closed-toe shoes. Hard hats and safety glasses will be provided for the portion of the trip where needed.

Host Sponsors: Hess Corporation and Legado Resources
Trip Coordinator: Bob Kiker – APTA



(8:00 am to 5:00 pm)



- 8:00 *Check-in at Midland Center*
- 8:30 *Buses Depart Midland Center Promptly*
- 9:45 *Arrive at Hess Offices in Seminole, Tx*
- 9:45-10:15 *Rest Stop, Briefing*
- 10:30-11:45 *Tour of Field Facilities*
- 12:00 *Return to Hess Offices for Buffet lunch*
- 12:00-1:00 *Lunch*
- 1:00 *Depart for Tour of Plant Facilities*
- 2:30 *Depart for Goldsmith*
- 3:30 *Goldsmith Landreth CO₂ Flood and Facilities*
- 4:00-4:15 *Goldsmith Rest Stop*
- 4:15-5:00 *Return Trip to Midland Center*



CO₂ Floods in the Permian Basin

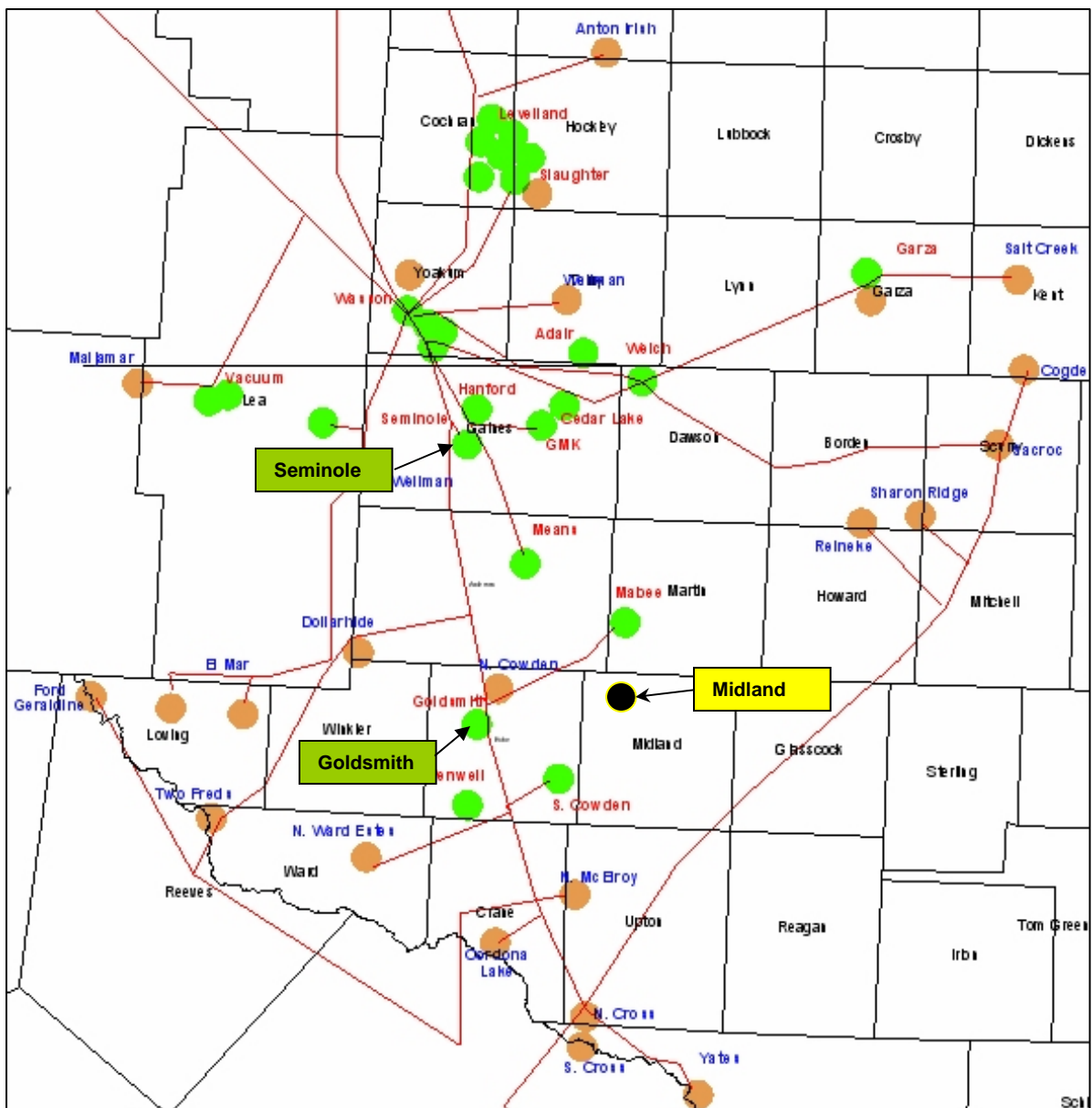

ACTIVE RESIDUAL OIL ZONE CO₂ EOR PROJECTS IN THE PERMIAN BASIN

MIDDLE SAN ANDRES PALEOGEOGRAPHY with Location of Industry Documented ROZ Zones/Fields*

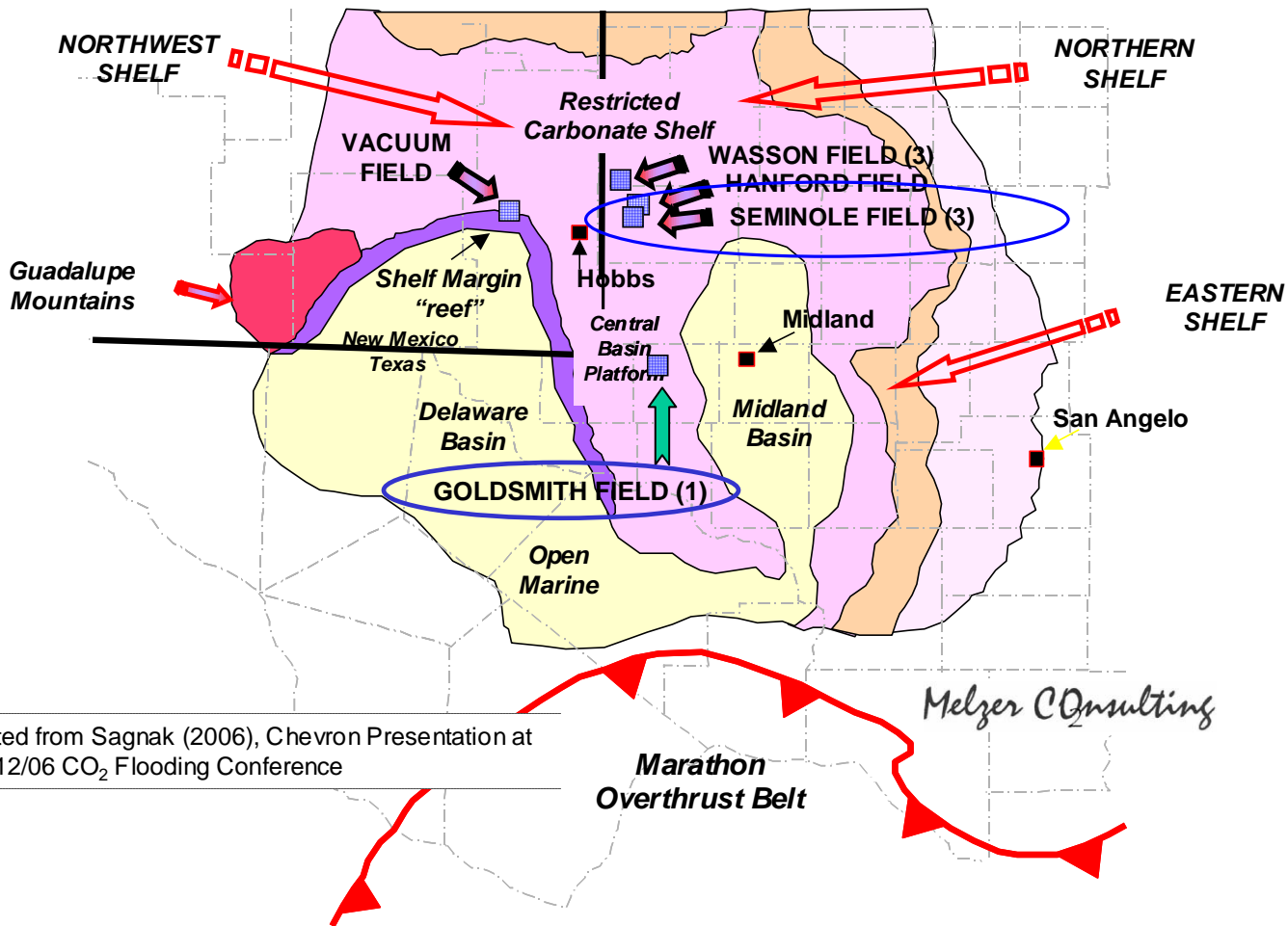

* Adapted from Sagnak (2006), Chevron Presentation at the 12/06 CO₂ Flooding Conference



MAP OF FIELD TRIP ROUTE

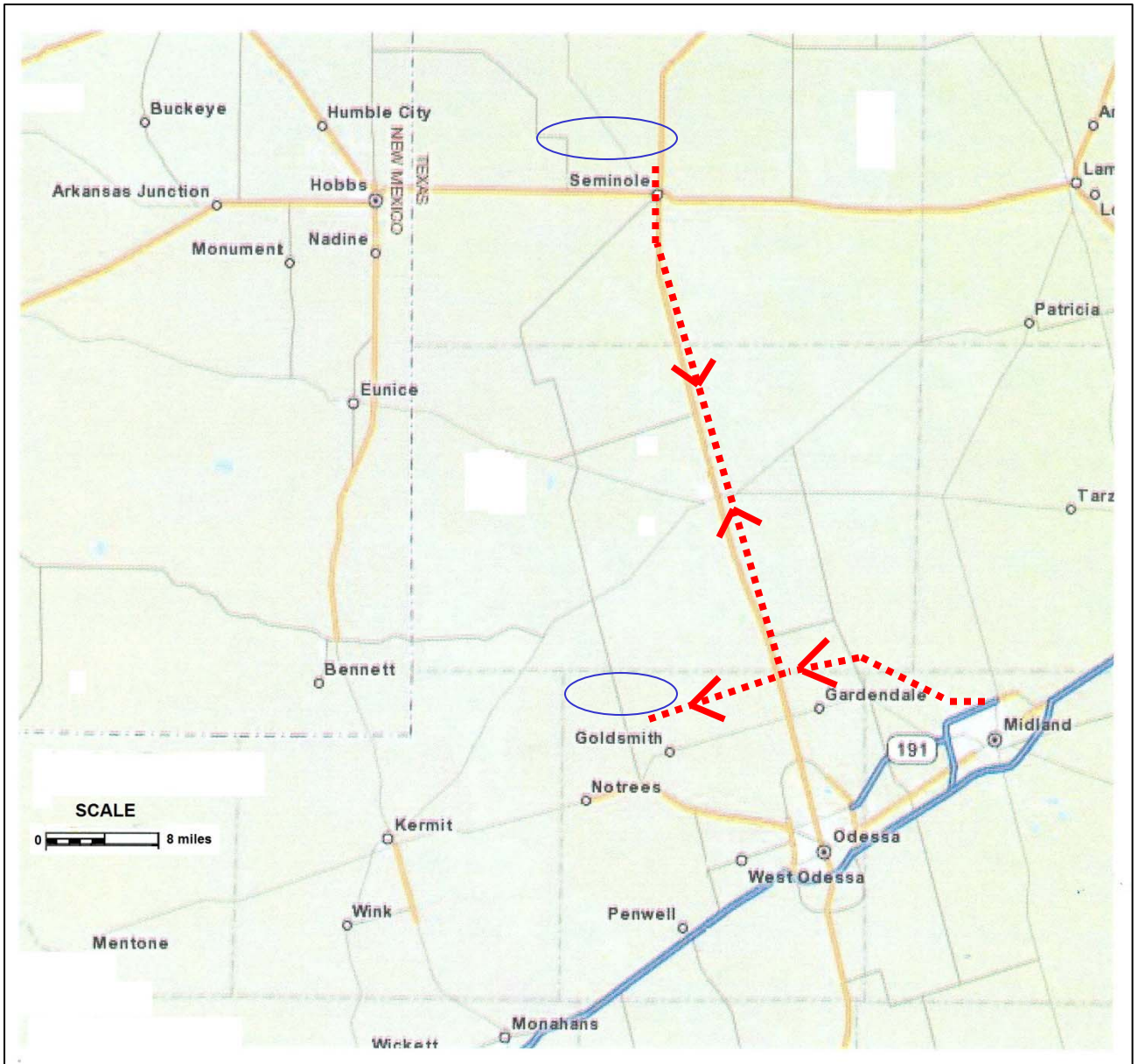

STOP NUMBER 1

THE SEMINOLE FIELD

Seminole San Andres Unit (SSAU)

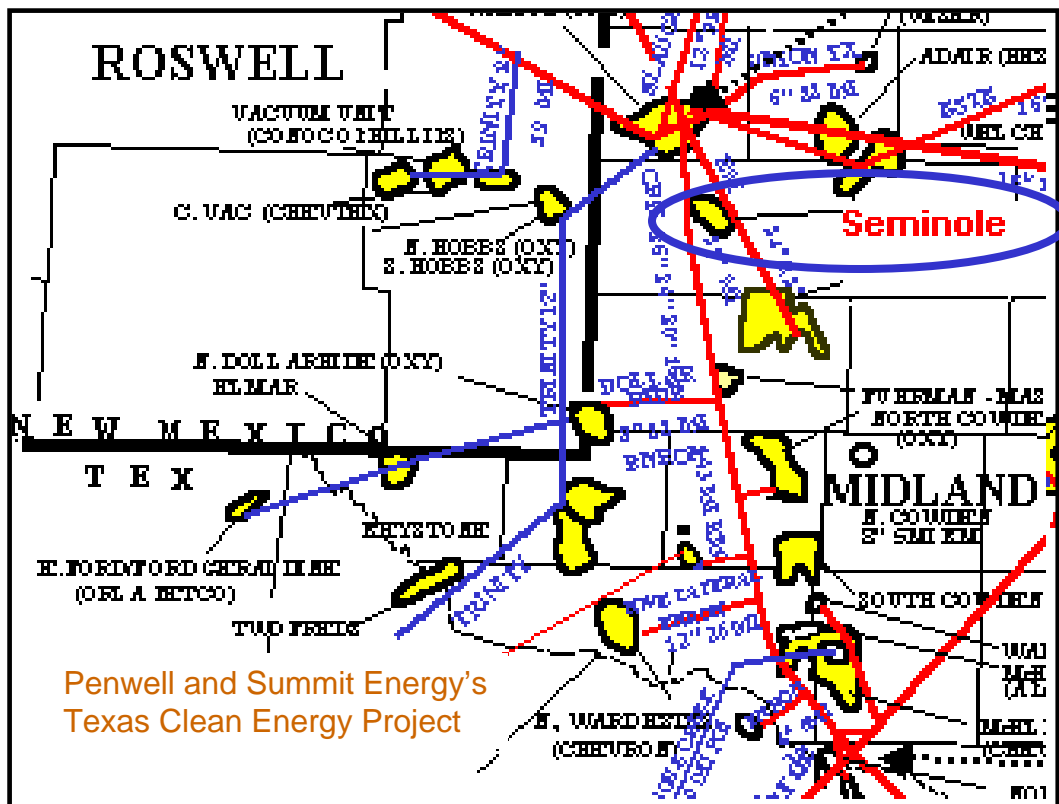

SSAU BACKGROUND

Seminole San Andres Unit SSAU Background

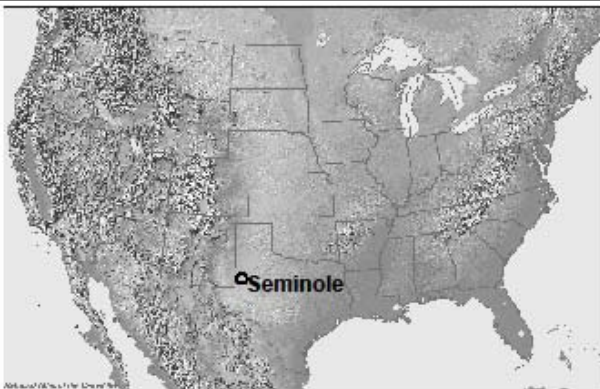

| | |
|---|-------------------------|
| Ownership | |
| Hess | 34.3% (operator) |
| OXY | 28.0% |
| ExxonMobil | 19.2 % |
| Marathon | 13.5 % |
| Chevron | 2.5 % |
| Others | 2.5 % |
| Location: Permian Basin, TX | |
| Wells: 368 prod 196 inj | |
| Facilities: SSGP Unit CO2 Recovery Plant | |

| | |
|------------------------------|--|
| Reservoir Description | Limestone and dolomite deposited in a shallow carbonate ramp environment |
| Fluid Type | Saturated black oil |
| Drive Mechanism | Gas in solution and gas cap during primary. External energy from water and CO2 injection during secondary and tertiary recovery. |
| Develop. History | 1936 Discovery 1936 First Production 1969 Unitized/Waterflood 1983 MPZ CO2 Flood Begins 1996 ROZ Phase 1 2004 ROZ Phase 2 2007 ROZ Stage 1 |
| Cumulative Production | 674 MMBO, 41 MMBOE NGL, 685 BCF HC Gas |
| Current Rate | 19.7 MBOPD, 242 MMCFD CO2+HC 28,113 MBOEPD (Oil+NGL+Gas) |

May 18, 2010

Reference: Biagiotti, S. (2010), Houston Section of the SPE Reservoir Study Group, May 2010

3



SSAU Field Flow Schematic

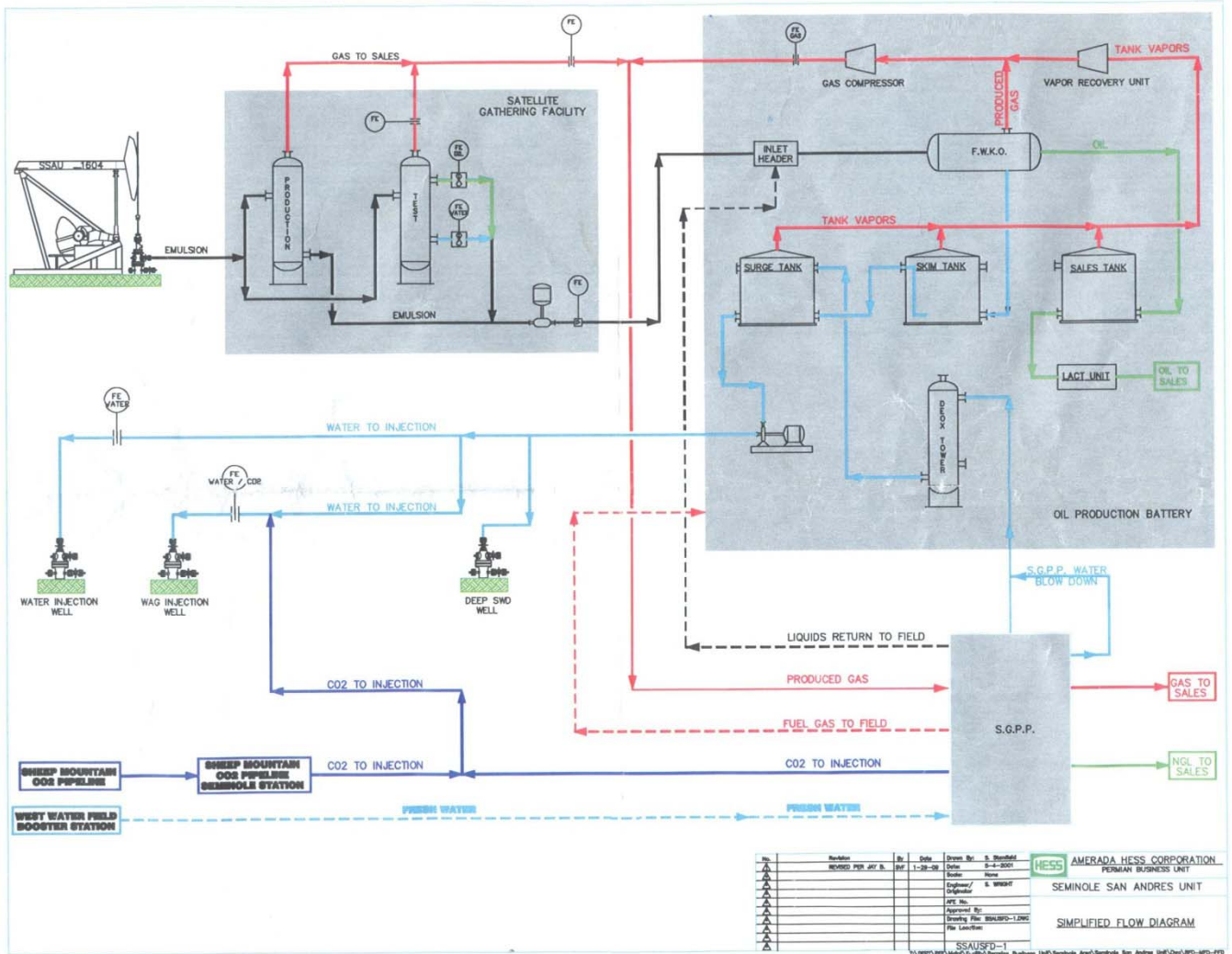

| No. | Revision | By | Date | Drawn By | S. Shepherd |
|-----|--------------------|-----|----------|---------------|---------------|
| 1 | REVISED PER JRY S. | SMF | 11-28-99 | Drawn | 2-4-2001 |
| 2 | | | | Revised | |
| 3 | | | | Engineer/ | |
| 4 | | | | Designer | |
| 5 | | | | JRF No. | |
| 6 | | | | Approved By | |
| 7 | | | | Drawing File | SSAUSFD-1.DWG |
| 8 | | | | File Location | |

SSAUSFD-1
V:\2001\SSAU\SSAU\Production\Business Unit\Seminoles Area\Seminoles San Andres Unit\Draw\SSFD-1.DWG

HESS AMERADA HESS CORPORATION
PERMANENT BUSINESS UNIT
SEMINOLE SAN ANDRES UNIT
SIMPLIFIED FLOW DIAGRAM



Overall Seminole Plant Schematic

ROZ SGPP Expansion to 280 MMSCFD

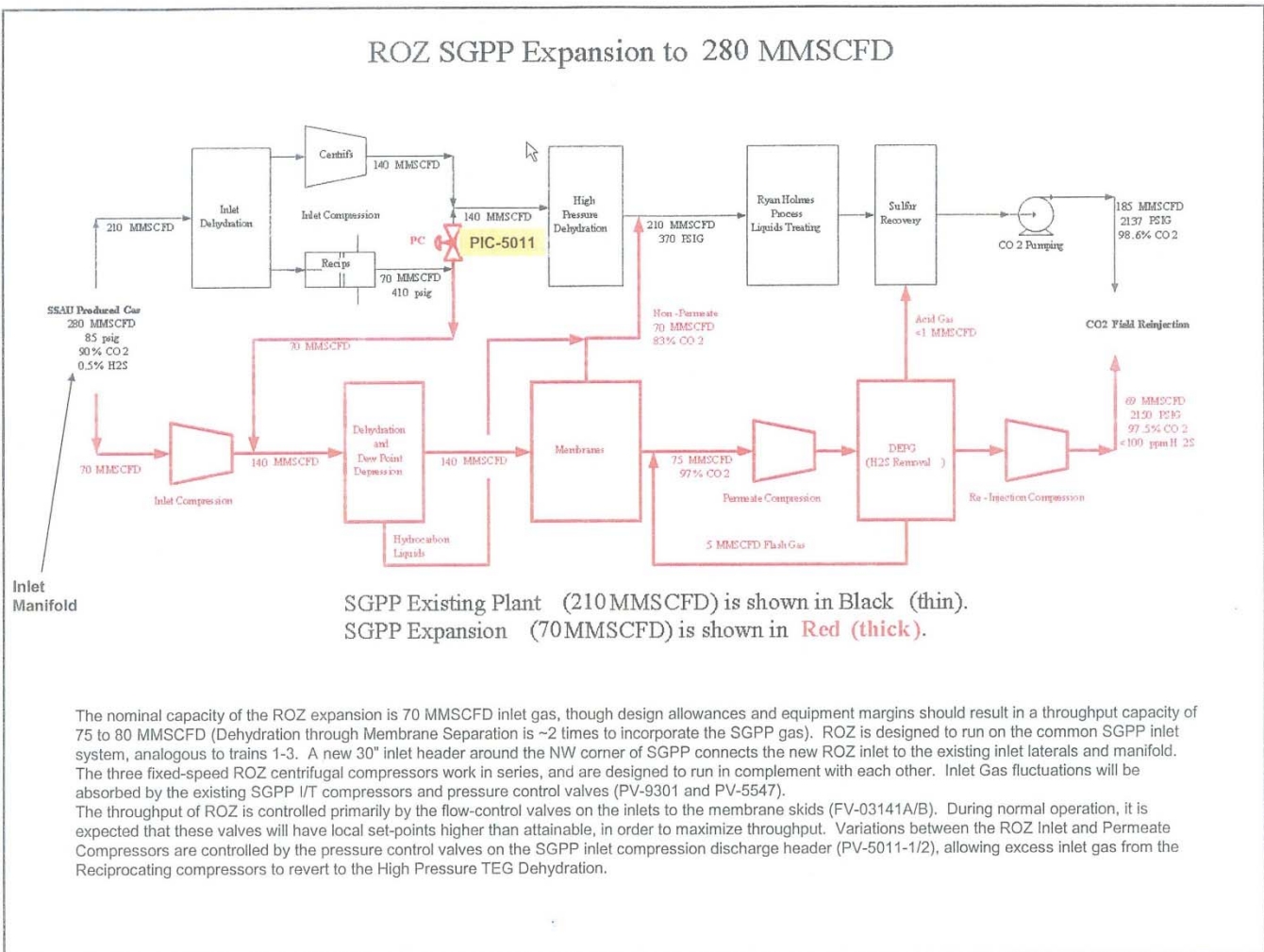

The nominal capacity of the ROZ expansion is 70 MMSCFD inlet gas, though design allowances and equipment margins should result in a throughput capacity of 75 to 80 MMSCFD (Dehydration through Membrane Separation is ~2 times to incorporate the SGPP gas). ROZ is designed to run on the common SGPP inlet system, analogous to trains 1-3. A new 30" inlet header around the NW corner of SGPP connects the new ROZ inlet to the existing inlet laterals and manifold. The three fixed-speed ROZ centrifugal compressors work in series, and are designed to run in complement with each other. Inlet Gas fluctuations will be absorbed by the existing SGPP I/T compressors and pressure control valves (PV-9301 and PV-5547). The throughput of ROZ is controlled primarily by the flow-control valves on the inlets to the membrane skids (FV-03141A/B). During normal operation, it is expected that these valves will have local set-points higher than attainable, in order to maximize throughput. Variations between the ROZ Inlet and Permeate Compressors are controlled by the pressure control valves on the SGPP inlet compression discharge header (PV-5011-1/2), allowing excess inlet gas from the Reciprocating compressors to revert to the High Pressure TEG Dehydration.

PROPERTIES OF THE ROZ

SSAU Sponge Core Data

Ref: SPE 133089

Selected Interval
"Average" Oil Saturation for ROZ

Oil/Water Contact

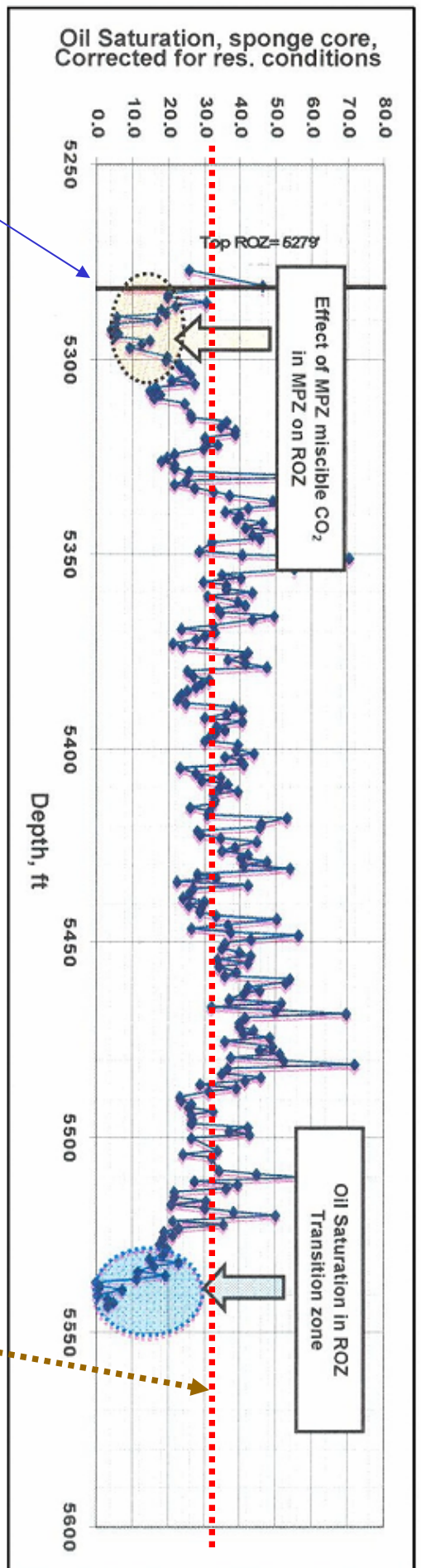

HISTORY OF ROZ DEVELOPMENT

Seminole San Andres Unit
ROZ Development

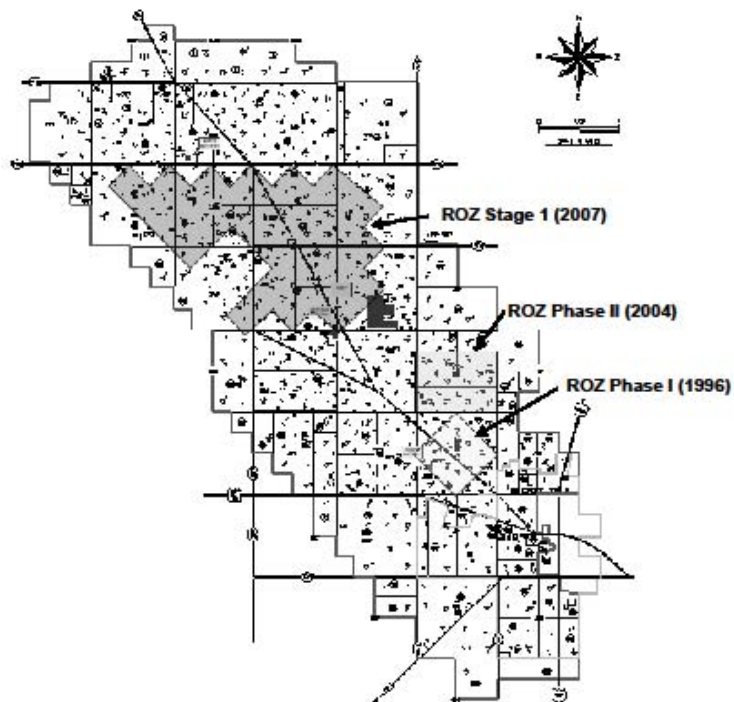

May 18, 2010

7



SSAU OIL RESPONSE* TO CO₂

SSAU TERTIARY (CO₂) PHASE OIL PRODUCTION AND ANALYSES

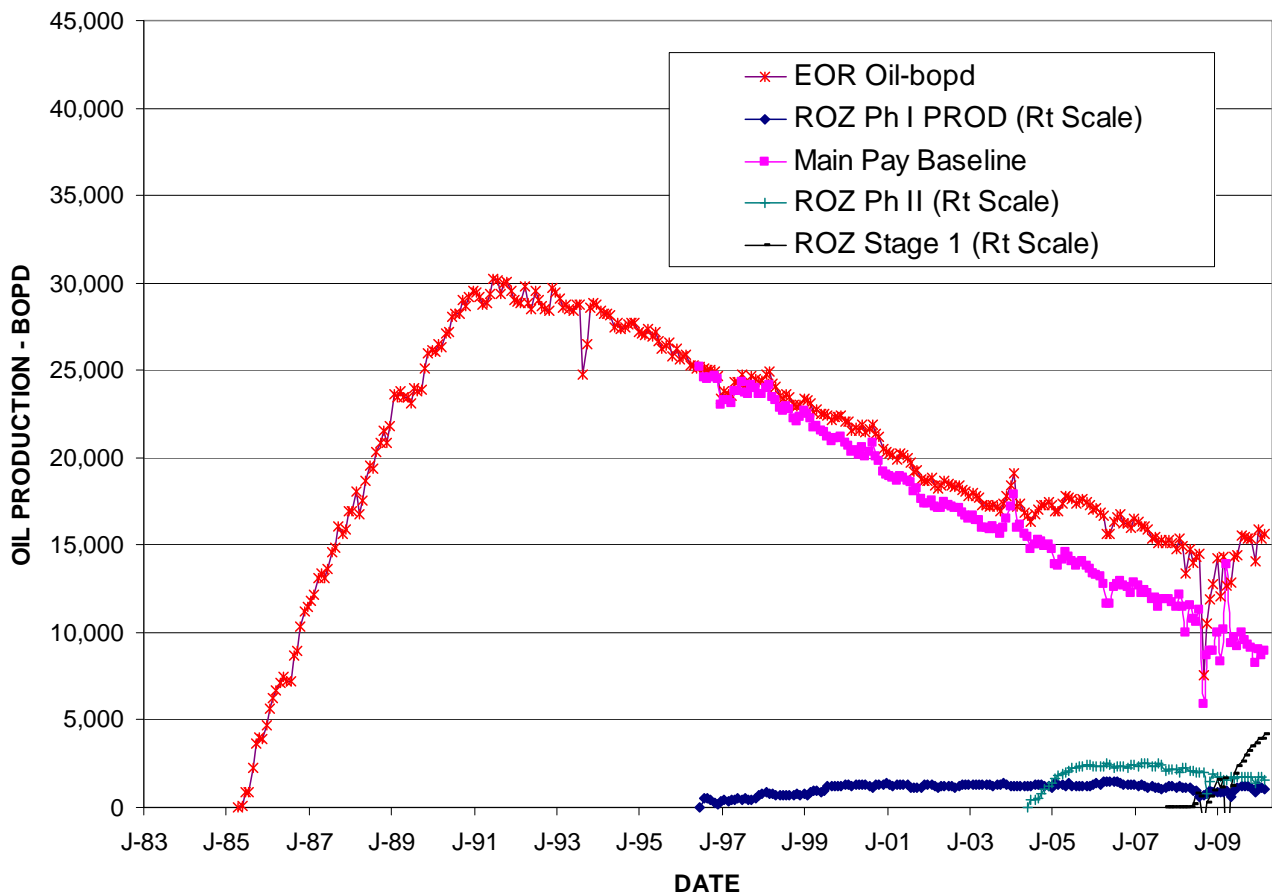

* Interpretations as per Melzer Consulting



STOP NUMBER 2

THE GOLDSMITH FIELD

Goldsmith Landreth

San Andres Unit (GLSAU)



Goldsmith Landreth San Andres Unit (GLSAU)

- 6,200 Acre San Andres Unit
- CO₂ ROZ Pilot in Place (as of 6/10, 4 Wells on CO₂ Injection 6 of 9 Producers Responding)
- Pilot Designed to Prove up ROZ Potential (More than Double CO₂ Reserves)
- Phase I Co-development of Main Pay and ROZ just underway (Nov '10)



Detailed GLSAU Background (1)

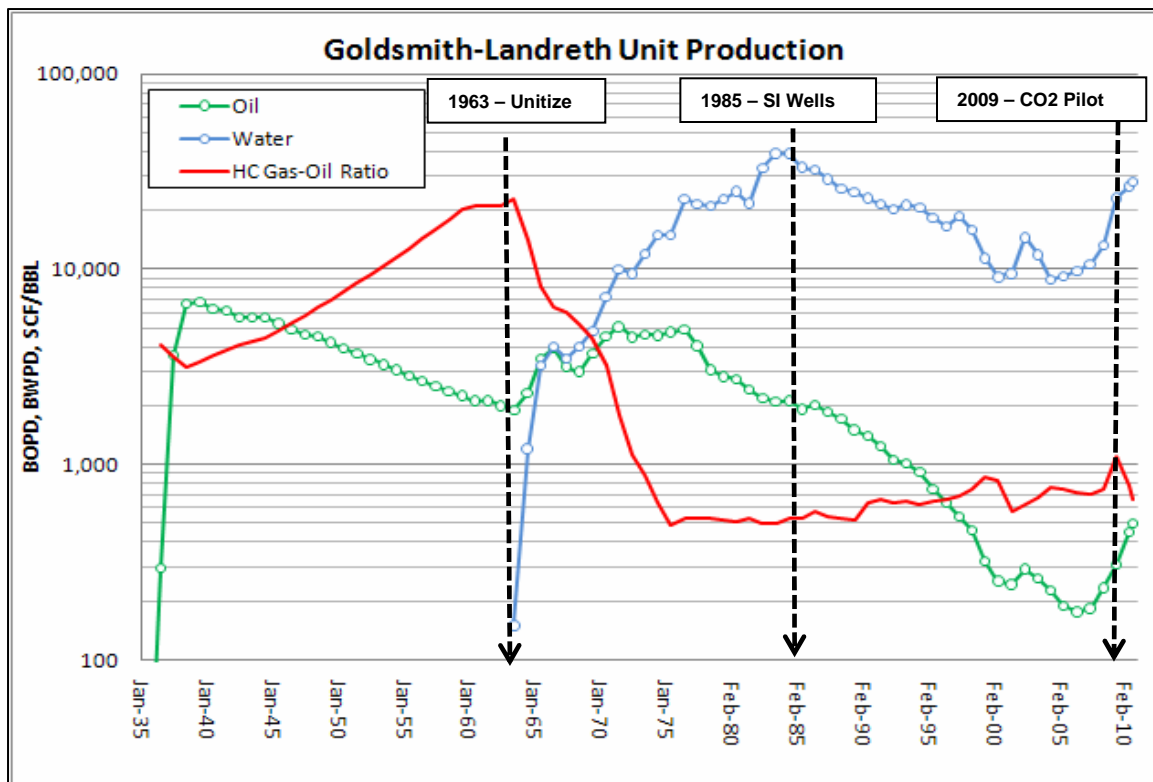

SAN ANDRES RESERVOIR DATA

| | | |
|--------------|-----------|-------|
| Unit Area | (ac) | 6166 |
| Well Spacing | (ac) | 20 |
| Depth | (ft) | 4200 |
| Pinit | (psi) | 1712 |
| Temp | (F) | 95 |
| API | (gravity) | 34 |
| MMP | (psi) | 1150 |
| Rsi | (scf/bbl) | 757 |
| Swc | (%) | 15-20 |
| Sorw | (%) | 38% |
| Porosity | (frac) | 0.11 |
| Permeability | (md) | 8 |

TIMELINE

Discovered in 1934 with 250 wells drilled by 1945
 Gas cap reinjection occurred from 1948 to 1969
 Unitized in 1963 with Amoco operating until 1996
 Initially a peripheral flood injecting below main pay
 Expanded to 40ac 5-spot patterns over ~20 yr span
 Water curtain ceased & oil migrated into gas cap
 Well abandonments in mid 80's accelerates decline
 Field pressure in 2008 varied from 1000 – 2000 psi
 Legado acquired in '08, Avg well 4 BOPD at 1% oil cut

Reactivated, deepened through ROZ, and cut core
 Convert from rod pump to ESP when ROZ added
 Installed CO2 pilot in 2009 at 5 MMCFD injection
 Expanded pilot to 4 pats 1Q-2010 at 16 MMCFD
 Install Ph 1 CO₂ by YE-2010 & ramp to 55 MMCFD



Detailed GLSAU Background (2)

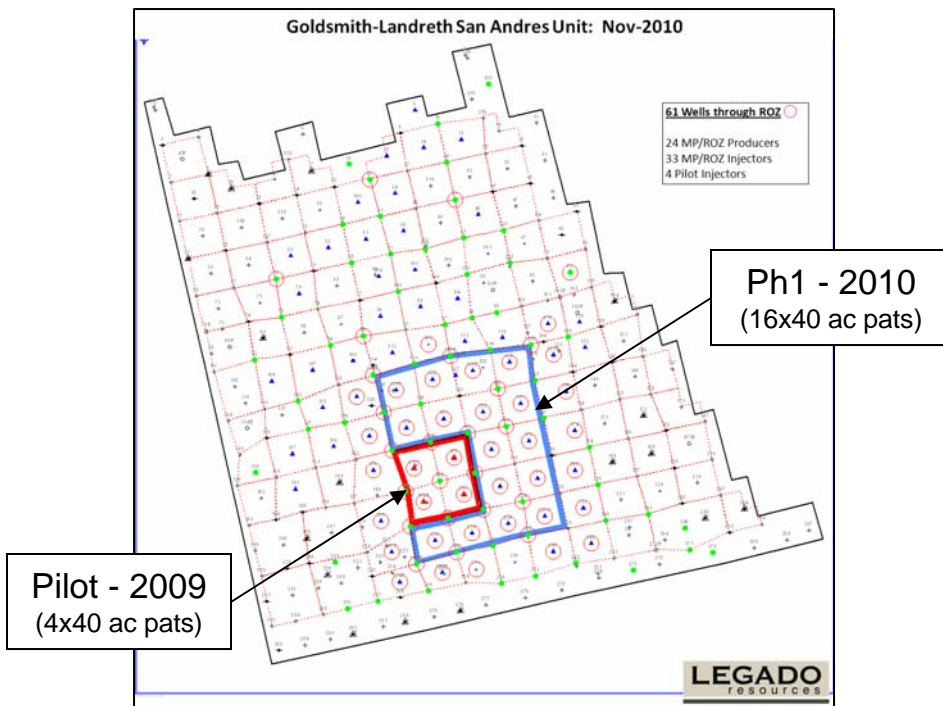

CO₂ FLOOD (2009-2010)

Well Utility (\$16.9 MM)

20 CO₂ injectors, 30 prods, 22 containment injectors

Facilities (\$23.6 MM, excluding NGL plant)

3.5 mile 8" pipeline (200 mmcf)

14 miles of injection line (3" laterals, 6"-8" trunk)

11 miles of flow line (3" flow line, 16" trunk)

3650 HP of compression (16 mmcf, 3 units)

Central Processing Facility (60,000 BFPD)

2 Test Satellites (16 prod/16 inj wells each)

NGL Processing Facility

Background

All CO₂ flood wells deepened through ROZ

Avg CO₂ injection 4.5 MMCFD/well

Pilot prod 300+ BOPD incremental to date



CO₂ Project Phase I Central Processing Facility Process Flow

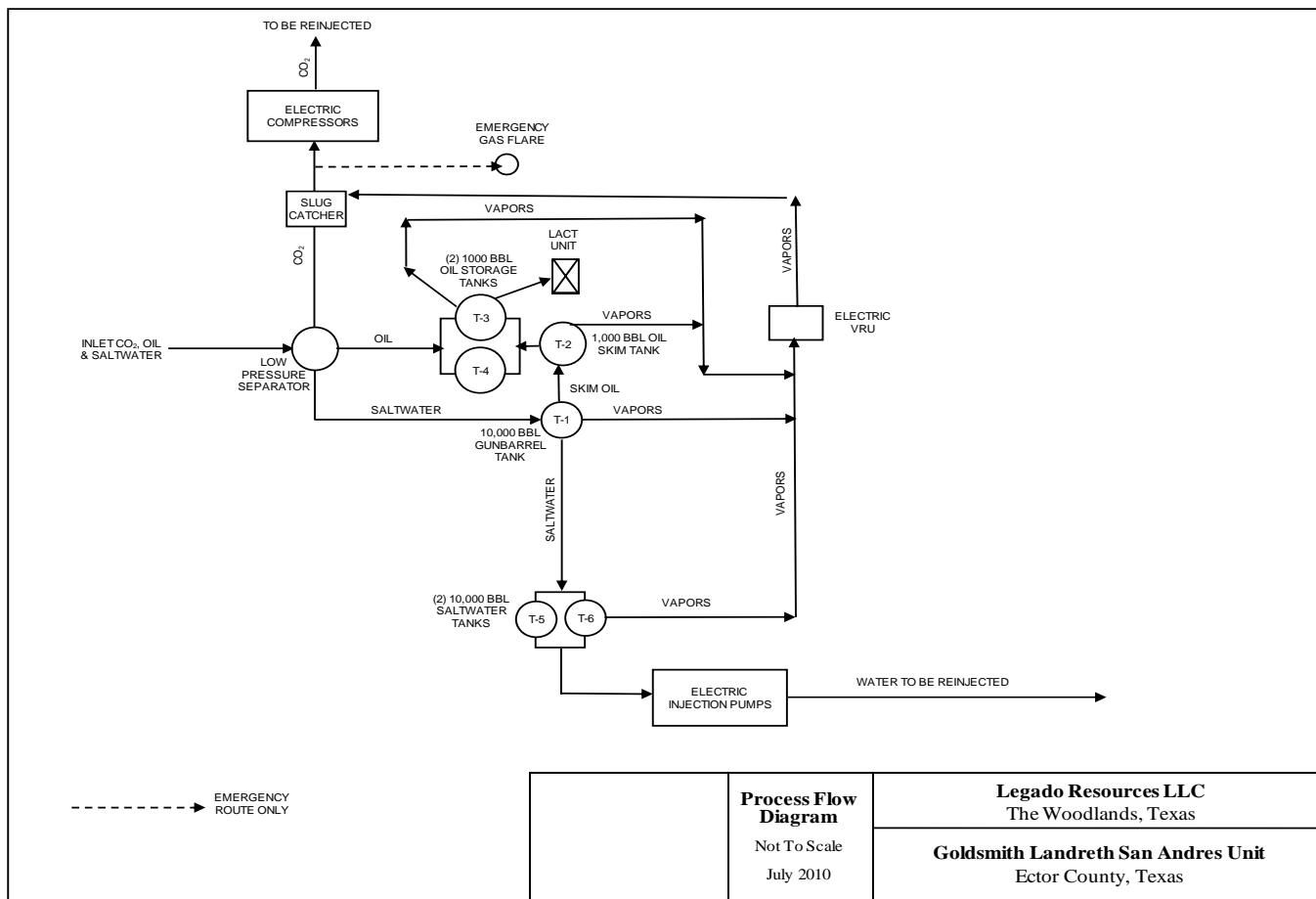

CO₂ EOR RESPONSE AT THE GLSAU

LEGADO GOLDSMITH SAN ANDRES "BROWNFIELD" CO₂ EOR (+ROZ) PRODUCTION

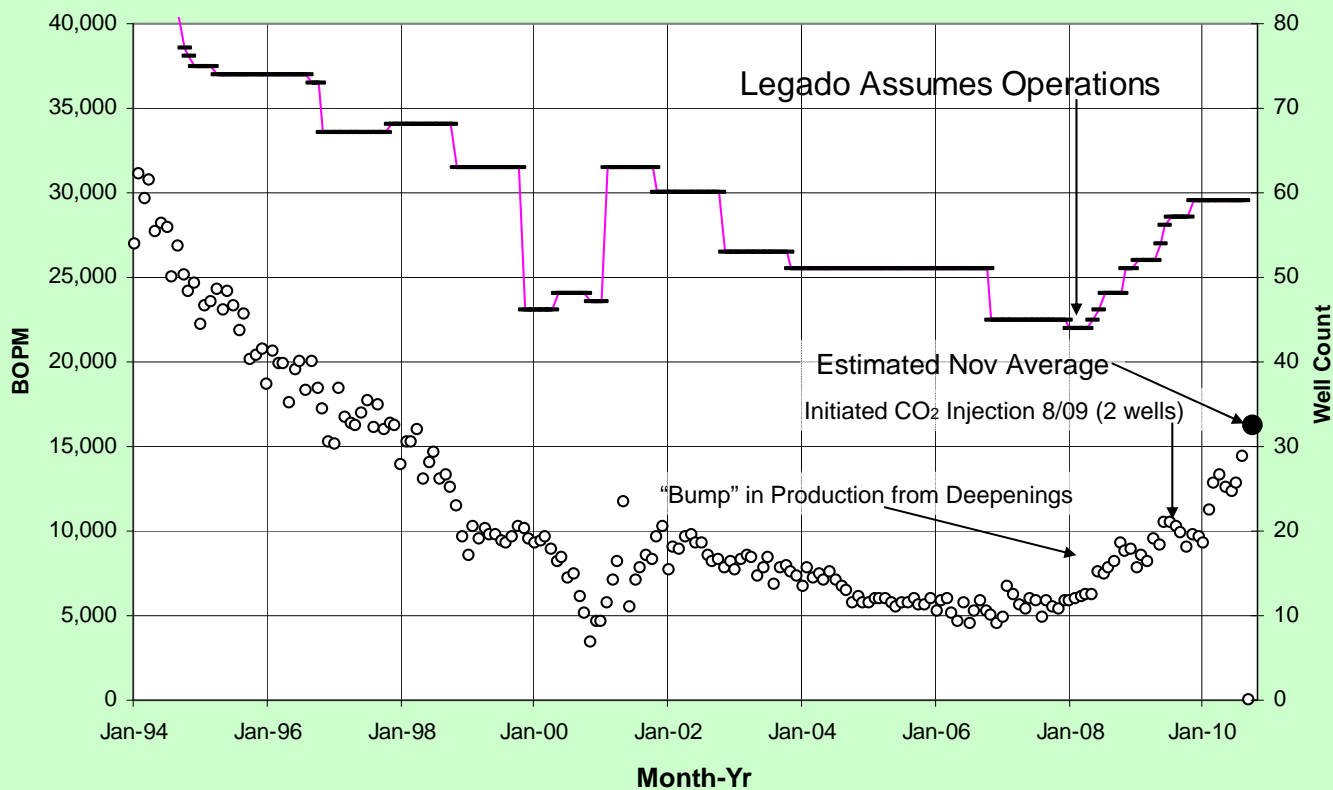

Thank You